



Steca Solsum

5.0F, 8.0F, 6.6F, 8.8F, 10.10F

The new Steca Solsum F-Line continues the huge success of one of the most used SHS controllers. With a power range of up to 10A at automatically recognized 12V or 24V it fits to a system sizes of maximum 240W.

The circuit board is completely electronically protected and with the new designed LED user interface it is easy to check the battery state of charge at any time. Large terminals guarantee a simple connection of solar panels, battery and load. The brand new Solsum works on PWM as a low loss serial controller.



Product features

- Voltage regulation
- Automatic selection of voltage
- Serial PWM control
- Multistage charging technology
- Current compensated load disconnection
- Automatic load reconnection
- Temperature compensation
- Common positive grounding or negative grounding on one terminal
- Night light function with Steca PA RC100
- Monthly maintenance charge

Electronic protection functions

- Overcharge protection
- Deep discharge protection
- Reverse polarity protection of load, module and battery

Automatic electronic fuse

- Short circuit protection of load and module
- Overvoltage protection at module input
- Open circuit protection without battery
- Reverse current protection at night
- Overheating and overload protection
- Battery overvoltage shutdown

Displays

- Multifunction LED display
- Multi-coloured LED
- 4 LEDs show operating statuses
- for operation, state of charge, fault messages

Operation

- Adjustable by remote control

Interfaces

- Steca Optobus

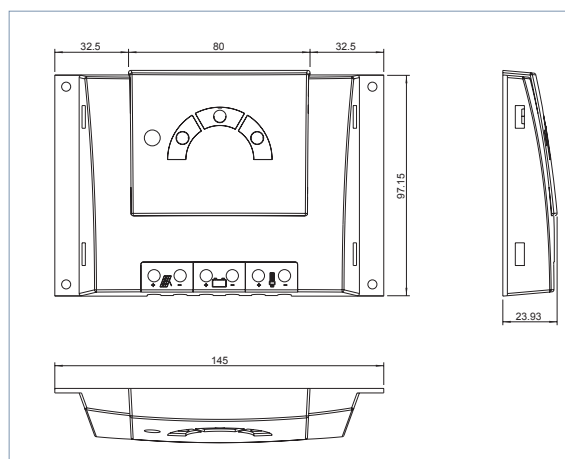

Technical Data	Solsum 5.0F	Solsum 8.0F	Solsum 6.6F	Solsum 8.8F	Solsum 10.10F
Display input data					
Open circuit voltage module	< 47 V				
Module current	5 A	8 A	6 A	8 A	10 A
DC output data					
Load current	5 A	8 A	6 A	8 A	10 A
End of charge voltage	13.9 V (27.8 V)				
Boost charge voltage	14.4 V (28.8 V)				
Reset voltage (SOC/LVR)	without LVR	> 50 % / 12.4 V ... 12.7 V (24.8 V ... 25.4 V)			
Deep discharge protection (SOC/LVD)	without LVR	< 30 % / 11.2 V ... 11.6 V (22.4 V ... 23.2 V)			
Operating behaviour					
System voltage	12 V	12 V (24 V)			
Self consumption	< 4 mA				
Applicaton conditions					
Ambient temperature	-25 °C ... +50 °C				
Equipment and design					
Terminal (finde / single wire)	4 mm ² / 6 mm ² - AWG 12 / 9				
Enclosure protection	IP 32				
Weight	approx. 150 g				
Dimensions (X x Y x Z)	145 x 97.15 x 23.93 mm				

Technical data at 25 °C / 77 °F

Certificates

- Compliant with European Standards (CE)
- RoHS compliant
- Developed in Germany
- Manufactured according to ISO 9001 and ISO 14001

[application area]

